

JLBIUCF 01

built-in freezer

Instruction manual

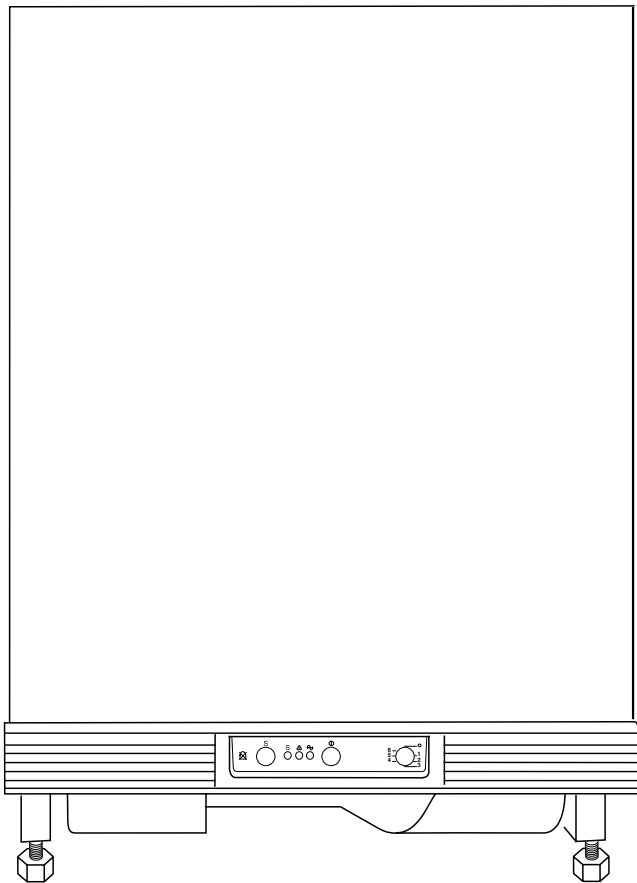

John Lewis

Important Safety Information

It is most important that this instruction book should be retained with the appliance for future reference. Should the appliance be sold or transferred to another owner, or should you move house and leave the appliance, always ensure that the book is supplied with the appliance in order that the new owner can get to know the functioning of the appliance and the relevant warnings.

These warnings have been provided in the interest of safety. You **MUST** read them carefully before installing or using the appliance. If you are unsure of the meanings of these warnings contact the John Lewis branch from which you purchased the appliance.

Installation

- Any electrical work required to install this appliance should be carried out by a qualified electrician or competent person.
- This appliance is heavy. Care should be taken when moving it.
- It is dangerous to alter the specifications or attempt to modify this product in any way.
- Care must be taken to ensure that the appliance does not stand on the electrical supply cable.
Important: if the supply cable is damaged, please contact our extended warranty administrators who will put you in touch with your local Service Force Repair Centre for further advice.
- Parts which heat up should not be exposed. Whenever possible, the back of the appliance should be close to a wall but leaving the required distance for ventilation as stated in the installation instructions.
- The appliance should be left for 2 hours after installation before it is turned on, in order to allow the refrigerant to settle.

Child Safety

- This freezer is designed to be operated by adults. Do not allow children to tamper with the controls or play with the product.
- Keep all packaging well away from children.

General Safety

- **This appliance contains hydrocarbons in its cooling unit; maintenance and recharging must therefore only be carried out by authorised technicians.**
- **Take utmost care when handling your appliance so as not to cause any damages to the cooling unit with consequent possible fluid leakages.**
- **The appliance must not be located close to cookers, radiators or boilers.**
- **Avoid prolonged exposure of the appliance to direct sunlight.**
- **Do not use other electrical appliances (such as ice cream makers) inside of refrigerating appliances.**

Use

- This appliance is designed for domestic use only, specifically for the storage of edible foodstuffs.
- Frozen food must **NOT** be re-frozen once it has thawed out.
- Do not place carbonated or fizzy drinks in the freezer.
- Do not remove items from the freezer if your hands are damp/wet, as this could cause skin abrasions or frost/freezer burns.
- Ice lollies can cause 'frost/freezer burns' if consumed straight from the freezer.
- Manufacturers' storage recommendations should be strictly adhered to. Refer to relevant instructions.
- The cooling plate or refrigerated freezer shelves in this appliance contain channels through which the refrigerant passes. If these are punctured this will cause substantial damage to the appliance and result in food loss. **DO NOT USE SHARP INSTRUMENTS** to scrape off frost or ice. Under **NO** circumstances should solid ice be forced off the lining or shelves. Solid ice should be allowed to thaw, when defrosting the appliance. See Defrost Instructions.

Maintenance and Cleaning

- Switch off and unplug the appliance before carrying out any cleaning or maintenance work.

Service

- This product should be serviced by an authorised engineer and only genuine spare parts should be used.

Environmental Information

- When disposing of your appliance, use an authorised disposal site.
- Remove the plug and ensure that any locks or catches are removed, to prevent young children being trapped inside.
- The symbol  on the product or on its packaging indicates that this product may not be treated as household waste. Instead it shall be handed over to the applicable collection point for the recycling of electrical and electronic equipment. By ensuring this product is disposed of correctly, you will help prevent potential negative consequences for the environment and human health, which could otherwise be caused by inappropriate waste handling of this product. For more detailed information about recycling of this product, please contact your local city office, your household waste disposal service or the shop where you purchased the product.

Contents

For the User

Important Safety Information	2
Description of the appliance	5
Control panel	13
Start your appliance	13
Temperature control	13
Before using	14
Freezing fresh food	14
Frozen food storage	14
Thawing	15
Making ice cubes	15
Normal operating sounds	15
Hints and Tips	16
Maintenance and Cleaning	17
Internal cleaning	17
When the appliance is not in use	17
Periodic cleaning	17
Defrosting	17
Something Not Working	18
Repairs - After Sales Service	19

For the Installer

Installation	6
Technical Specification	6
Electrical Connection	6
Positioning	6
Door Reversal	8
Building In	9

Guide to use the Instruction Manual

The following symbols will be found in the text to guide you throughout the instructions:

 **Safety instructions**

 **Hints and tips**

 **Environmental information**

This appliance complies with the following **E.E.C. Directives:**



- * **73/23 - 90/683** (Low Voltage Directive);
 - * **93/68** (General Directive);
 - * **87/308** (Radio Interference Suppression);
 - * **89/336** (Electromagnetic Compatibility Directive)
- and subsequent modifications.

Description of the Appliance

- 1 Frozen food storage compartments
- 2 Freezing fresh food compartment
- 3 Control panel

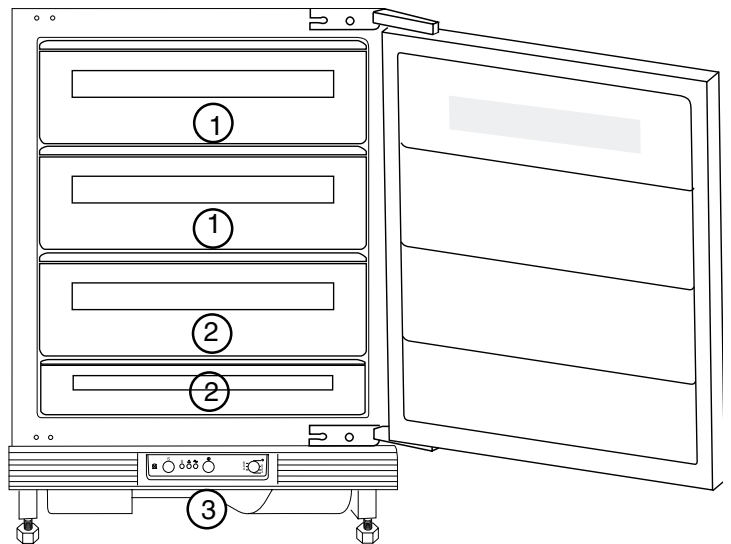

Installation

 It is dangerous to alter the specifications or attempt to modify this product in any way.

 Care must be taken to ensure that the appliance does not stand on the electrical supply cable.

Technical Data

Dimensions of recess

Height	820 mm
Width	600 mm
Depth	550 mm

Dimensions of the appliance cavity

Height	815 mm
Width	596 mm
Depth	550 mm

Freezer Gross capacity 108 litres

Freezer Net capacity 100 litres

Electrical connection

Any electrical work required to install this appliance should be carried out by a qualified electrician or competent person.

WARNING: THIS APPLIANCE MUST BE EARTHED.

The manufacturer declines any liability should this safety measure not be observed.

If the plug that is fitted to your appliance is not suitable for your socket outlet, it must be cut off and the appropriate plug fitted.

Remove the fuse from the cut off plug.

The cut off plug should then be disposed of to prevent the hazard of shocks in case it should be plugged into a 13amp socket in another part of your home.

Important

The wires in the mains lead are coloured in accordance with the following code:

Green and Yellow	- Earth
Blue	- Neutral
Brown	- Live

If you fit your own plug, the colours of the wires in the mains lead of your appliance may not correspond with the markings identifying the terminals in your plug, proceed as follows:

 Any electrical work required to install this appliance should be carried out by a qualified electrician or competent person.

Heating elements rating

Supply voltage (50 Hz) 220-230 V

Connected load, 90 W

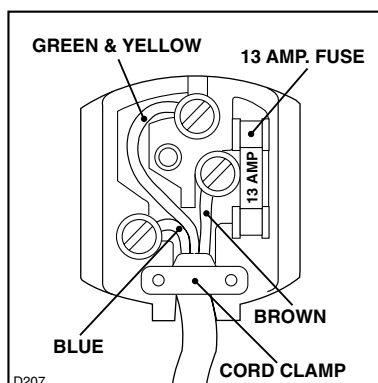

1. Connect the Green and Yellow (earth) wire to the terminal in the plug which is marked with the letter «E» or the earth symbol  or coloured green and yellow.
2. Connect the blue (neutral) wire to the terminal in the plug which is marked with the letter «N» or coloured black.
3. Connect the brown (live) wire to the terminal in the plug which is marked with the letter «L» or coloured red.
4. Upon completion there must be no cut, or stray strands of wire present and the cord clamp must be secure over the outer sheath. The plug moulded onto the lead incorporates a fuse. For replacement, use a 13amp BSI362 fuse. Only ASTA or BSI approved fuses should be used.

The plug must not be used if the fuse cover/carrier is lost. The cover/carrier is indicated by the coloured insert at the base of the plug.

A replacement cover/carrier must be obtained from your local Service Force Centre.

Warning

IF YOU ARE DISCARDING AN OLD APPLIANCE THAT HAS A LOCK OR CATCH ON THE DOOR, YOU MUST ENSURE THAT IT IS MADE UNUSABLE TO PREVENT YOUNG CHILDREN BEING TRAPPED INSIDE.

Depending upon the position which you choose for your appliance, you may wish to reverse the way in which the door opens. To do this, refer to instructions on “Door reversal directions”.

Positioning

This appliance should only be installed at a location where the ambient temperature corresponds to the climate classification indicated on the rating plate, which is located at the left on the inside of the appliance.

The following table shows which ambient temperature is correct for each climate classification:

SN	+10°C to +32°C
N	+16°C to +32°C
ST	+18°C to +38°C
T	+18°C to +43°C

It should be located in a dry atmosphere, out of direct sunlight and away from extreme temperature e.g. not next to a boiler or radiator, or in a very cold room e.g. an outhouse. If these temperatures are exceeded i.e. colder or warmer, then the appliance may not operate correctly.

For building-in and door reversibility, if necessary, refer to the relevant instructions in the following pages.

Important

It must be possible to disconnect the appliance from the mains power supply; the plug must therefore be easily accessible after installation.

Door Reversal

To reverse the opening direction of the door, proceed as shown in the figures:

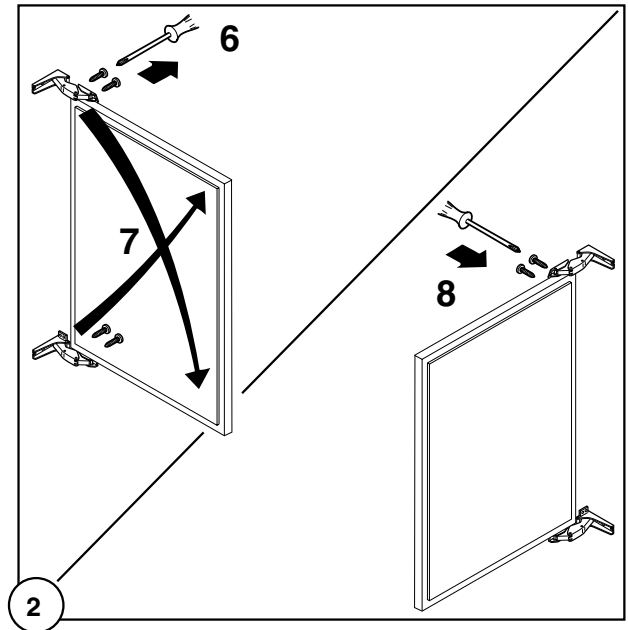
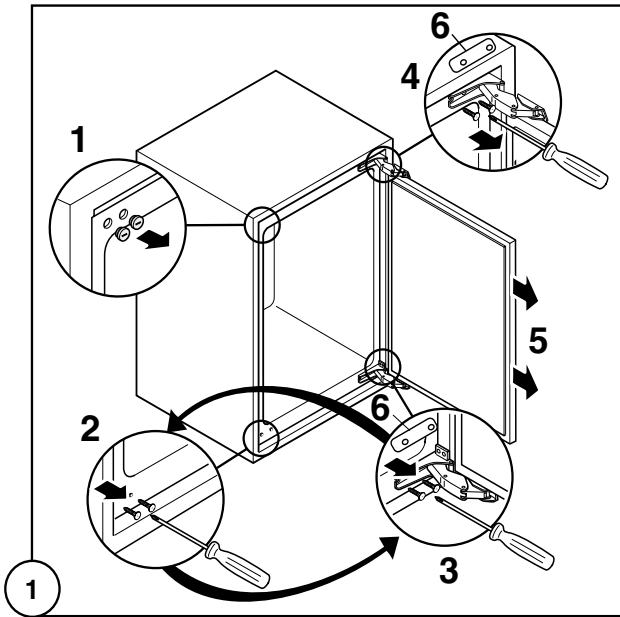

Warning

After completion of the door reversing operation, check that the door gasket adheres to the cabinet. If the ambient temperature is cold (i.e. in Winter), the gasket may not fit perfectly to the cabinet. In that case, wait for the natural fitting of the gasket or accelerate this process by heating up the part involved with a normal hairdryer on a low setting.

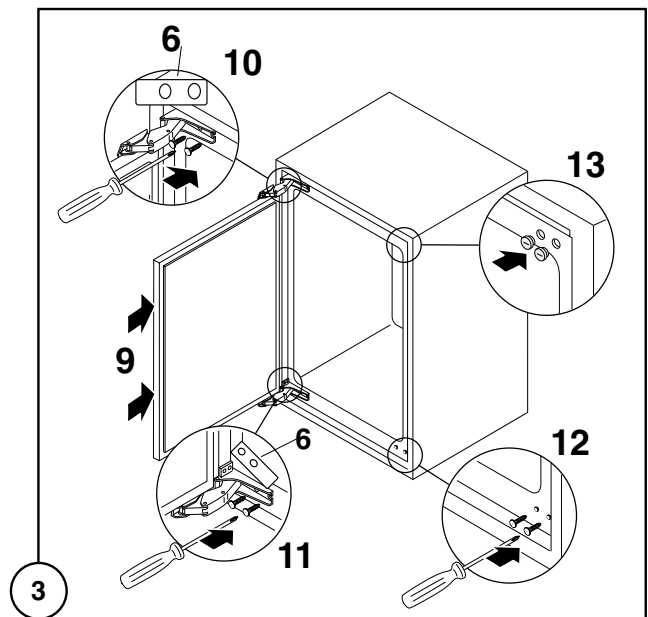

i Building In

Before carrying out any work, remove the plug from the power socket.

Grid preparation

Left door opening:

Remove the left side (A) of the grid cutting it from the rear (see figure).

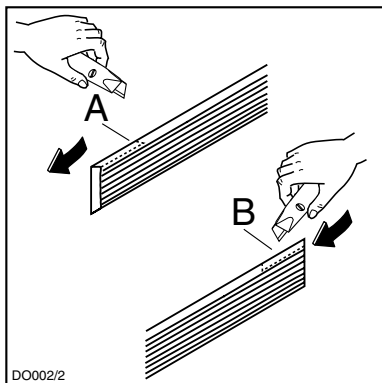

Right door opening:

Remove the right side (B) of the grid cutting it from the rear (see figure).

To position the grid on the appliance proceed as follows:

Apply the grid to the base of the appliance by pushing on to the clasps (a) until they click.

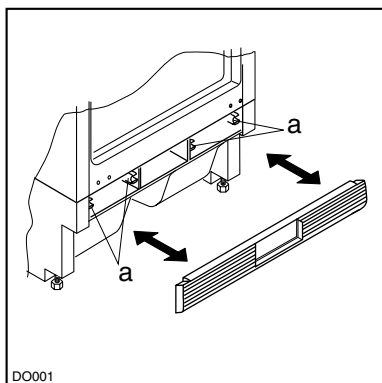

Building in the appliance under a worktop

The dimensions of the recessed installation area must correspond with those indicated in the figure.

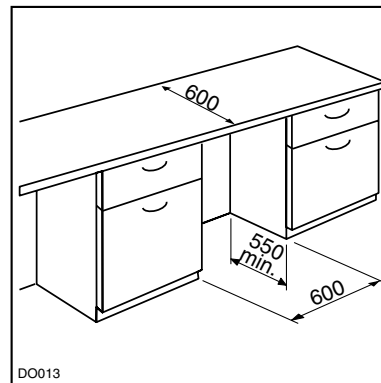

Installation kit

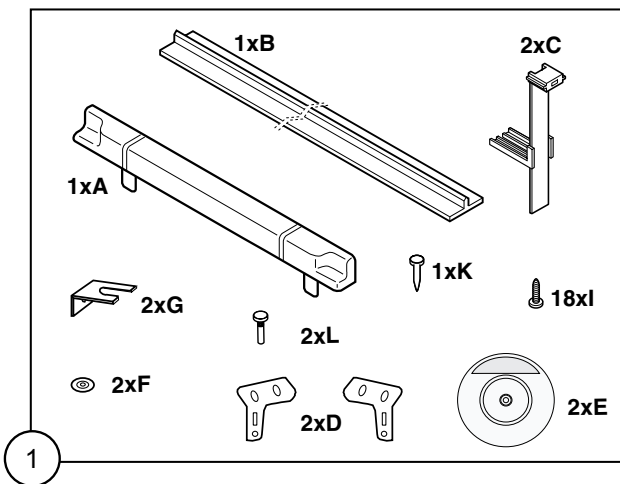

1. Two cabinet securing brackets are supplied with the installation pack. They need to be assembled onto the cabinet prior to cabinet being pushed into the Kitchen aperture.

- To fit these brackets remove the two screws at the top left and right hand front corners of the cabinet.
- Position the two brackets as shown in the figure and replace the two securing screws.

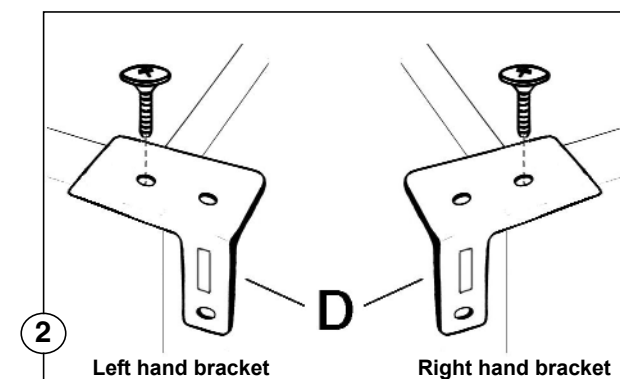

2. Push the appliance into place. The plug socket necessary for connection of the appliance to the electricity supply should be positioned, so that the plug is not placed in the recess.
3. To adjust the height proceed as follows:
 - Loosen or tighten the two front feet.
 - The rear feet are adjusted by turning the screw in the front kick plate to the left or right.

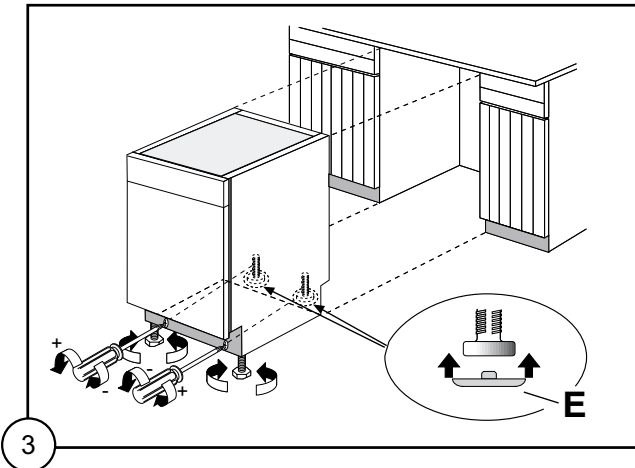

If necessary, pads (E) are supplied for the rear feet to make sliding the appliance in and out of the recess easier. To fit the pads, press them onto the rear feet. If required, the dimensions of these pads can be reduced by breaking them where marked.

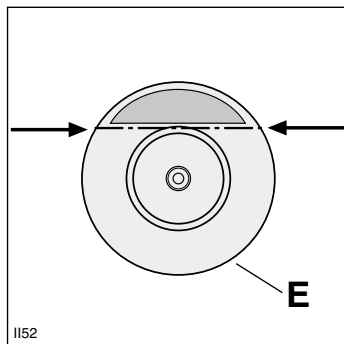

4. The joint cover (B) is to be assembled after having installed the appliance in the recess.

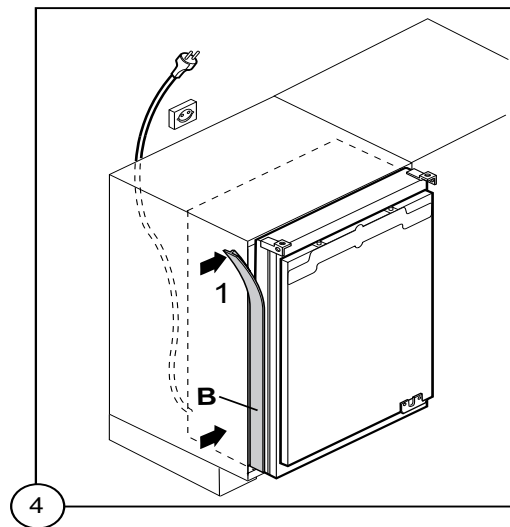

5. Screw appliance into place and retain the cabinet with screws (I) through the securing brackets into the worktop or adjacent woodwork as necessary.

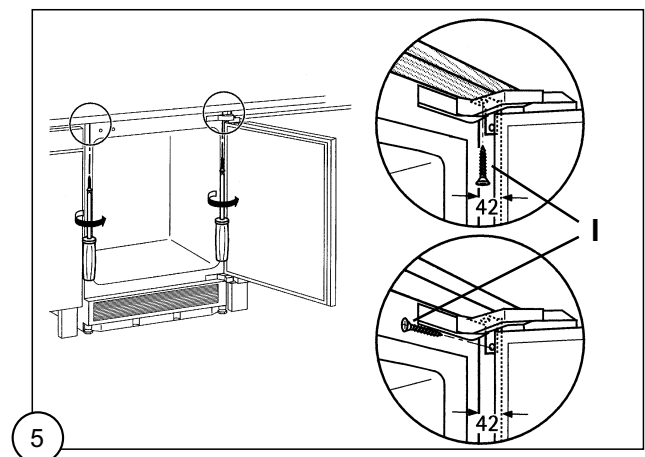

6. To mount the furniture door proceed as shown in the figures:

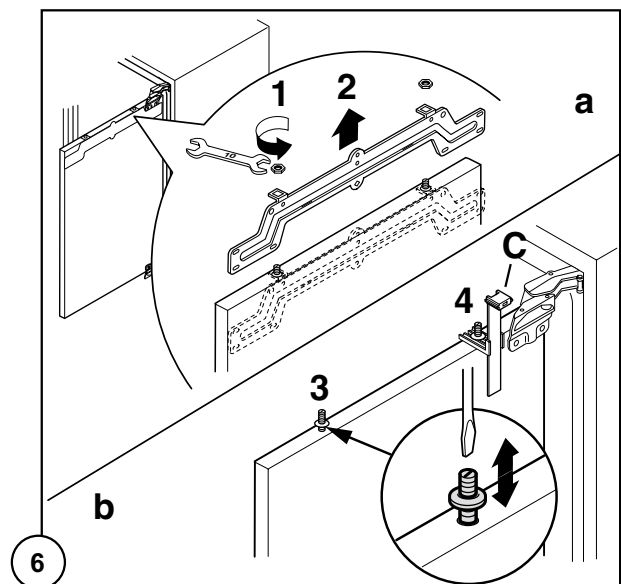

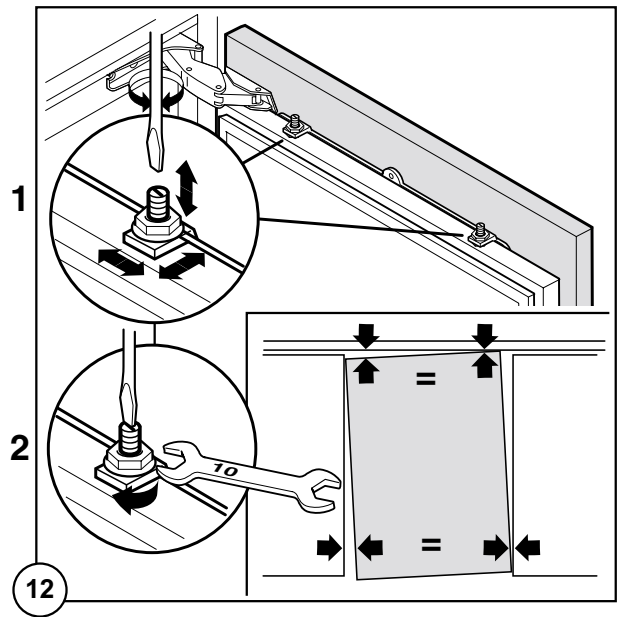
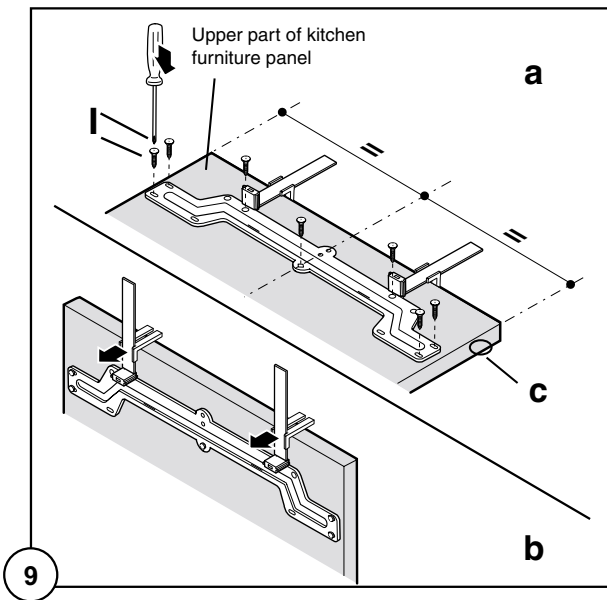
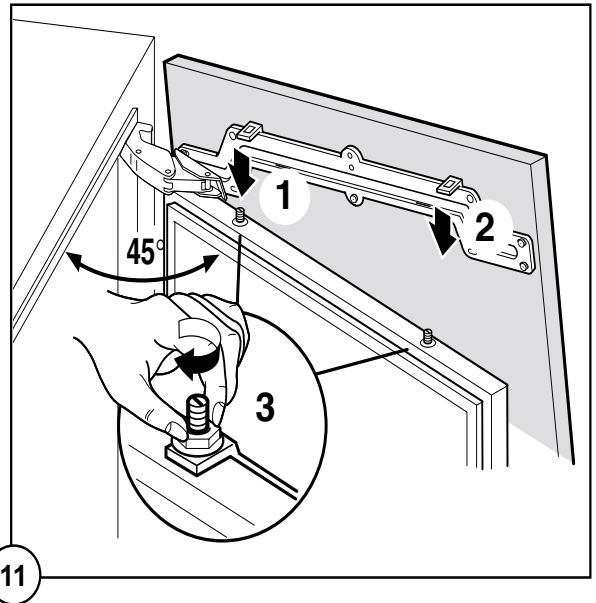
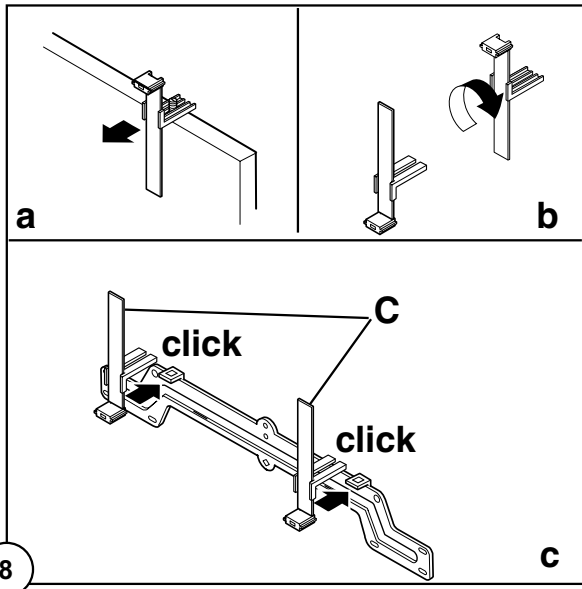
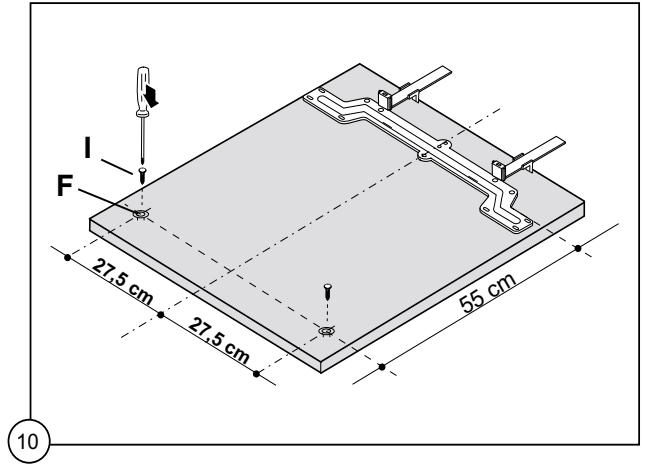
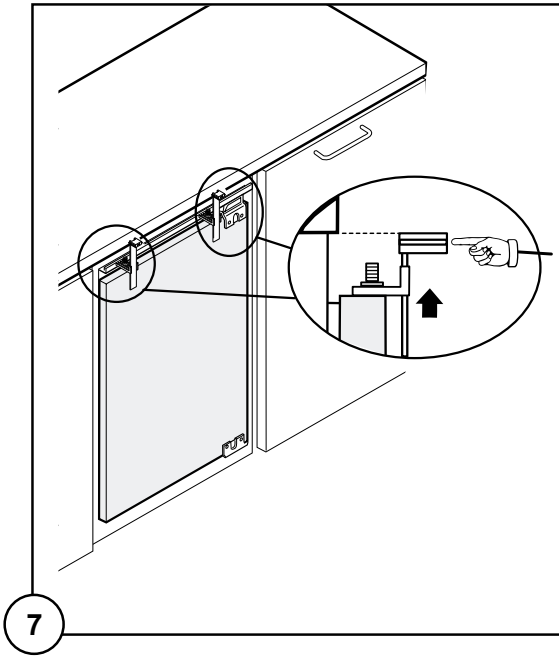

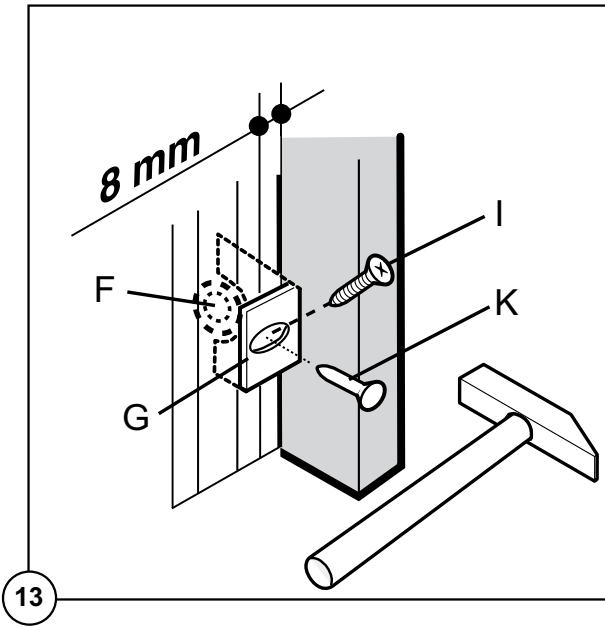

13

7. Refit the covering strip (A).

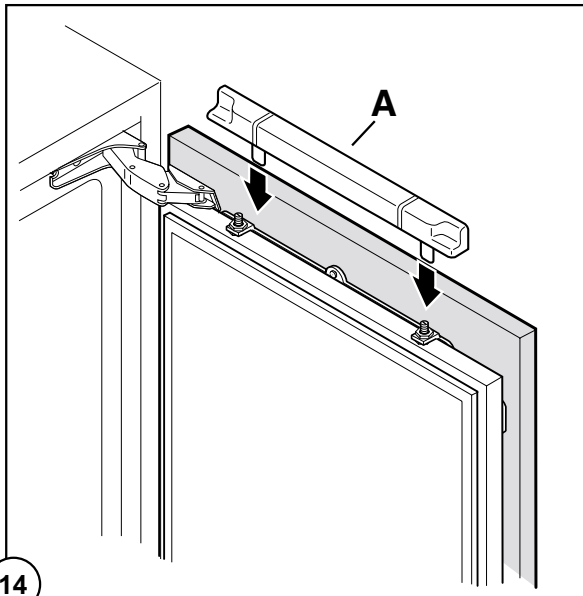

14

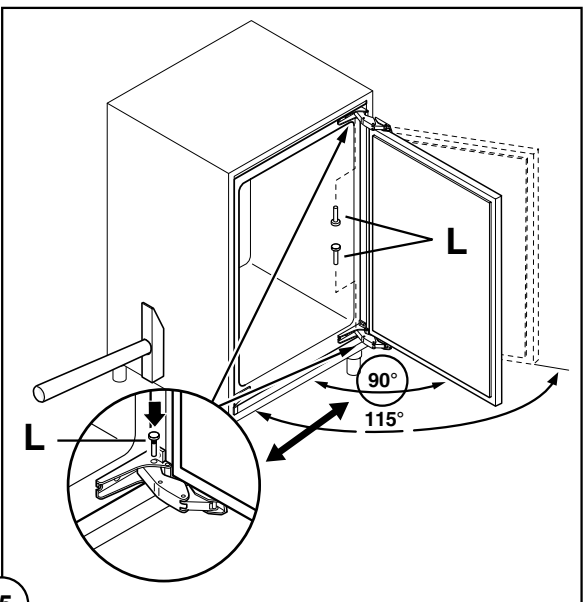

15

12

Fitting the plinth



Important

For the efficient operation of the appliance, it is important that the original ventilation grid is used.

- For an opening height dimension $A=820$ mm and a plinth height dimension $a=100$ mm, the plinth may be fitted without adjustments. The same applies to an opening height dimension $B=870$ mm and a plinth height dimension $b=150$ mm.
- For plinth heights greater than $a=100$ mm, $b=150$ mm, a cut should be made in the plinth, 580 mm wide, in the centre of the appliance position, leaving a remaining height of $a=100$ mm, $b=150$ mm.
- Attach plinth to the kitchen units.

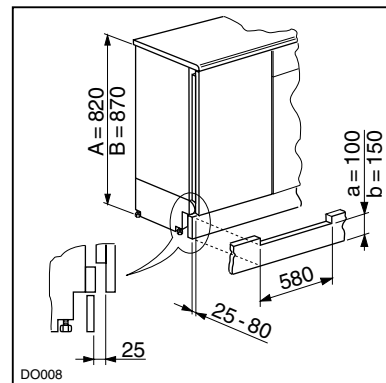

Important

The plinth must be positioned at a minimum distance of 25 mm from the door.

The Control Panel

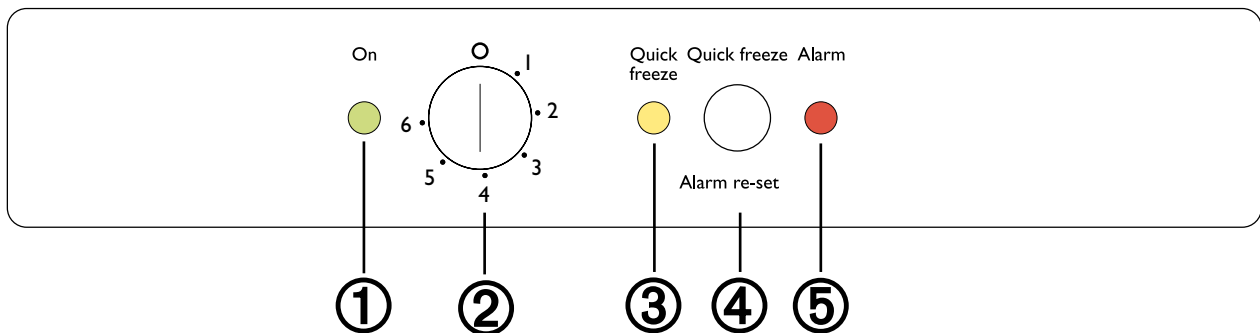

- 1 Pilot light
- 2 Thermostat control knob
- 3 Fast-freezing indicator light
- 4 Push button for fast-freezing and for stopping the audible signal (warning light on)
- 5 Warning light

Start your appliance

Insert the plug into the wall socket. The appliance can be activated by turning the thermostat knob (2) beyond the «O» position. When the pilot light (1) is illuminated, this shows that the appliance is on.

Temperature control

The temperature within the freezer is controlled by the thermostat control knob (2) situated at the bottom of the cabinet.

To operate the freezer proceed as follows:

Position 1 = minimum coldness

Position 6 = maximum coldness

Turn the thermostat control knob beyond the «O» position.

When you first start the freezer, we suggest that you turn the thermostat control to a medium setting. For easier turning of this control, use a small coin. The internal temperature of the freezer is automatically adjusted by the thermostat to ensure safe food storage.

However, if the appliance is working in unfavourable room conditions such as

- poor ventilation,
- high temperature,
- frequent door openings,

it may be necessary to select a more suitable setting.

Warning light (red)

If the temperature warning light (4) blinks, it indicates that the temperature within the freezer has reached a level where the safe food storage is no longer ensured.

When the freezer is first switched on, the warning light will blink until the temperature has dropped to a safe level for the storage of frozen food.

Temperature acoustic alarm

This appliance incorporates an alarm which gives off an audible signal whenever the warning light comes on. This signal can be temporarily stopped by depressing the push button for fast-freezing (4). The fast-freezing push button can be released as soon as the warning light is off.

Open door acoustic alarm

This appliance also incorporates an alarm which sounds if the door is left open for more than 60 seconds. The signal will be stopped when the door is closed again.

Before using

Remove all securing tapes. Wash inside the appliance with lukewarm water and bicarbonate of soda (5 ml to 0.5 litre of water).

Do not use soap or detergent as the smell may linger. Dry thoroughly.

Freezing fresh food

In any 24 hour period you can freeze up to 18 kg of fresh food.

Activate fast freeze by depressing the fast-freeze switch (4) 24 hours before you want to freeze your fresh food, the yellow light (3) illuminates.

If the quick-freezing function is not ended manually, the appliance switch off the quick-freezing function after 52 hours. The yellow light goes out.

This time can be shortened, depending on the quantity of food to be frozen. After the time has elapsed place the food to be frozen in the two top compartments of the freezer as this is the coldest part; if freezing only a small amount of food, always use the top compartment.

Once the food is completely frozen (which could take up to 24 hours) press the fast freeze switch to deactivate the fast freeze mode; the yellow light (3) goes off.

Distribute the frozen food packages in the other compartments, so that the top compartments can be used for a further freezing operation.

Only freeze top quality, fresh and thoroughly cleaned foodstuffs.

Do not allow fresh food to touch food which is already frozen.

During the freezing process, ensure that the freezer door remains closed.

Frozen food storage

When you first start the freezer or if the freezer has been out of use for some time, we advise you to run your appliance for at least two hours in the «fast freeze» mode before storing frozen food.

To obtain the best performance from this appliance, we strongly recommend that you make sure that the commercially frozen foodstuffs were adequately stored by the retailer and, furthermore, be sure that these frozen foodstuffs are transferred from the foodstore to the consumer in the shortest possible time (a temperature increase of the frozen food could shorten its storage period).

It is also advisable not to exceed the storage period indicated by the producer of the food.

Finally, do not open the door frequently or leave it open longer than is absolutely necessary.



Warning

Do not put carbonated liquids, (fizzy drinks etc.), in the freezer compartment.

Ice lollies, if consumed immediately after removal from the freezer, can possibly result in a low temperature skin burn.

Do not remove items from the freezer if your hands are damp/wet, as this could cause skin abrasions or "frost/freezer burns".

If there is a power failure during the storage of frozen food, do not open the door during the whole time of the power failure. If the freezer is fully loaded, the frozen food will not be affected if the power cut is of short duration; otherwise, it is recommended to consume the food within a very short time.

Thawing

Frozen food, prior to being used, can be thawed in the fridge or at room temperature depending on the time available. Small food items may even be cooked from frozen; in this case cooking will take longer.

Any frozen food which is allowed to thaw accidentally should either be eaten as soon as possible or thrown away. Alternatively, if the food is uncooked and has not been completely defrosted it can be cooked and then refrozen.

Meat, fish and fruit should be thawed in the refrigerator compartment and small pieces of meat can even be cooked while still frozen, but you must ensure that it is thoroughly cooked through.

Vegetables should be directly immersed in boiling water; ready-cooked dishes can be placed directly in the oven in their aluminium wrapping.

A microwave oven is particularly suitable for thawing any type of frozen or deep-frozen food: follow the oven instructions, particularly regarding the placement of aluminium wrapping or containers in the oven.

Defrosted cooked food must never be refrozen.

Making ice cubes

The appliance is provided with one or more trays for ice-cubes trays.

Fill the tray(s) 3/4 full to give the ice space to expand and place them in the freezer compartment.

To release the ice cubes simply give the tray a slight twist.

Do not use sharp or metallic instruments to remove the trays from the freezer.

Normal Operating Sounds

- You may hear faint gurgling or bubbling sounds when the refrigerant is pumped through the coils or tubing at the rear, to the cooling plate/evaporator or to the fixed freezer shelves.
- When the compressor is on, the refrigerant is being pumped round, and you will hear a whirring sound or pulsating noise from the compressor.
- A thermostat controls the compressor, and you will hear a faint 'click' when the thermostat cuts in and out.

Hints and Tips

Food Storage

- To obtain the best results from your appliance, neither hot foods nor liquids which may evaporate, should be placed in the larder compartment.
- Keep the time between buying chilled food and placing it in your fridge as short as possible.
- Do not push food together too much, try to allow air to circulate around each item.
- Do not store food uncovered.
- Remove suspect food from your refrigerator and clean, refer to 'Maintenance and Cleaning'.
- Ensure that food placed in the freezer is dated and labelled and used in date order to ensure that food is consumed at its best.
- Avoid buying frozen food if you cannot store it straight away. The use of an insulated container is advisable. When you arrive home place the frozen food in the freezer immediately.
- The symbols on the drawers show different types of frozen goods. The numbers indicate storage times in months for the appropriate types of frozen goods. Whether the upper or lower value of the indicated storage time is valid depends on the quality of the foods and pre-treating before freezing.

Energy Saving Advice

- Do not install the cabinet close to sources of heat, i.e. boiler or radiator.
- Locate the appliance in a cool well ventilated room and make sure that the air openings of the cabinet are not obstructed.
- Avoid unnecessary frosting in the cabinet by packing all foodstuffs into airtight packages before placing them in the freezer.
- Always leave warm food to cool down to room temperature before placing in the fridge or freezer.
- Food which is to be frozen (when cool) should be placed in the fridge before being transferred to the freezer.
- Thaw frozen food in the fridge. This will ensure safer defrosting of foods and reduce the work of the refrigeration unit.

- Try to avoid keeping the door open for long periods, or opening the door too frequently as warm air will enter the cabinet, and cause the compressor to switch on unnecessarily often.
- Ensure there are no obstructions preventing the door from closing properly.

In the Event of a Power Failure

If there is a power failure during the storage of frozen foods, keep the door closed. If the temperature within your freezer should rise do not refreeze the food without checking its condition. The following guidelines should assist you.

Ice Cream:

Once thawed should be discarded.

Fruit and Vegetables:

If soft should be cooked and used up.

Bread and Cakes:

Can be refrozen without danger.

Shellfish:

Should be refrigerated and used up quickly.

Cooked Dishes:

i.e. casseroles, should be refrigerated and used up.

Large Pieces of Meat:

Can be re-frozen providing there are ice crystals remaining within them.

Small Joints:

Should be cooked and then re-frozen as cooked dishes.

Chicken:

Should be cooked and re-frozen as a fresh dish.

Maintenance and Cleaning

Before any maintenance or cleaning work is carried out, **DISCONNECT** the appliance from the **ELECTRICITY** supply.

Internal cleaning

Clean the inside and accessories with warm water and bicarbonate of soda (5ml to 0.5 litre of water). Rinse and dry thoroughly.

! NEVER USE DETERGENTS, ABRASIVE POWDERS, HIGHLY PERFUMED CLEANING PRODUCTS OR WAX POLISHES, TO CLEAN THE INTERIOR AS THESE WILL DAMAGE THE SURFACE AND LEAVE A STRONG ODOUR.

When the appliance is not in use

When the appliance is not in use for long periods, disconnect from the electricity supply, empty all foods and clean the appliance, leaving the doors ajar to prevent unpleasant smells.

Periodic cleaning

The appliance is equipped with a ventilation grid. Keep clean to guarantee good ventilation and good working order of the appliance.

An accumulation of dust will affect the performance of the appliance and cause excessive electricity consumption.

The structure of the appliance permits cleaning of the rear zone close to the wall, using a vacuum cleaner.

1. Remove the plinth (1), then the ventilation grid (2);
2. Carefully pull the air deflector out (3).

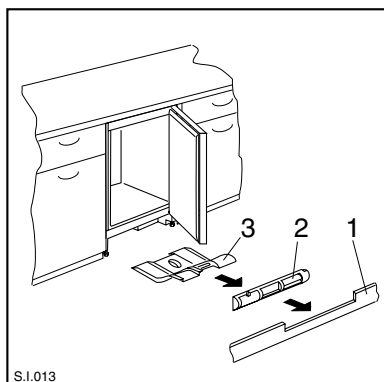

Defrosting

The freezer compartment will become progressively covered with frost. This should be removed with the special plastic scraper provided, whenever the thickness of the frost exceeds 1/4".

During this operation it is not necessary to switch off the power supply or to remove the foodstuffs. However, when the ice becomes very thick on the inner liner, complete defrosting should be carried out and it is advisable to carry out this operation when the appliance is empty.

To carry out complete defrosting proceed as follows:

1. Remove any stored food, wrap it in several layers of newspaper and put it in a cool place.
2. Turn the thermostat control knob (1) to the «O».
3. Leave the door open.
4. Remove the three large drawers.
5. When defrosting is completed, remove the water that has collected in the small bottom drawer and dry the interior thoroughly.

Turn the thermostat control knob to a medium setting and, after letting the appliance run for at least two hours in the «fast freeze» mode, replace the previously removed food into the compartments.

! Important
A temperature rise of the frozen food packs during defrosting may shorten their storage life.

Never use sharp metal tools to scrape off frost from the evaporator as you could damage the appliance beyond repair.

Something not working

Important: If you call out an engineer to a fault listed below, or to repair a fault caused by incorrect use or installation a charge will be made, even if the appliance is under guarantee.

Before contacting your local Service Force Centre, check the following points:

SYMPTOM	SOLUTION
<ul style="list-style-type: none"> ■ No power to the appliance 	<ul style="list-style-type: none"> ◆ Check there is power at the socket. ◆ Check there is not a power cut by checking the household lights. ◆ Check the fuse has not blown.
<ul style="list-style-type: none"> ■ The temperature in the freezer section is too high 	<ul style="list-style-type: none"> ◆ Check the thermostat control knob mounted in the cross piece between the fridge and freezer is turned to the correct setting relative to ambient conditions. ◆ Check the ambient temperature is within the appliance's operating limits, please refer to the installation section in this instruction book. Relocate the appliance if necessary.
<ul style="list-style-type: none"> ■ The freezer door will not open 	<ul style="list-style-type: none"> ◆ Has door just been opened? If so leave for a few minutes to allow the air pressure to equalise.
<ul style="list-style-type: none"> ■ The compressor runs continuously 	<ul style="list-style-type: none"> ◆ Adjust the thermostat control knob to give correct temperature control. See "Setting the temperature". ◆ Check that the doors are closed. ◆ Large quantities of food have recently been placed in the cabinet and/or door is frequently opened. ◆ Check that air ventilation is not obstructed.
<ul style="list-style-type: none"> ■ Excessive frost and ice has built up 	<ul style="list-style-type: none"> ◆ Ensure the doors are not left open. ◆ Check that nothing is preventing the doors from closing. ◆ Is the door gasket intact and clean. ◆ Has advised periodic defrosting been carried out?
<ul style="list-style-type: none"> ■ Noise 	<ul style="list-style-type: none"> ◆ Refer to normal operating sounds.

Repairs - After Sales Service

If your appliance is not performing satisfactorily; consult the fault finding guide within this instruction book (Something not working). In the event of a fault occurring which you cannot resolve yourself from advice given within this instruction manual your first step is to contact our extended warranty administrators on **0870 0107887** who will give you details for your local Service Force Repair Agent.

When contacting the repair agent, please quote the model (Mod.) and serial number (S.N.), both of which are shown on the rating plate located on the side of the oven door (see picture).

So that you always have these numbers at hand, we recommend you to make a note of them here:

Mod. :

PNC :

S.N. :

Your appliance is covered by a 3 year parts and labour guarantee (see separate details given at point of sale). Please retain your purchase receipt safely for the service engineer to verify the purchase details.

Spare parts

This product should be serviced by an authorised service engineer, and only genuine spare parts should be used.

Under no circumstances should you attempt to repair the appliance yourself.

Repairs carried out by inexperienced persons may cause injury or serious malfunctioning. Contact our extended warranty administrators on **0870 0107887** who will give you details for your local Service Force Repair Agent.

Always insist on genuine spare parts.

Manufacturer	John Lewis
Model	JLBIUCF01
Energy Efficiency class	
Energy Consumption kWh/year	208
Fresh food volume l	100
Star Rating	